

FLAVORSEAL® Pumps and Pump Stations

Product Name: Mid-Size Pump with Angle Sealer

General Description

Mid-Size pump filler is ideal for pumping a wide variety of liquid or semi-liquid products with or without particulates into bags, casings or other containers.

Features

The mid size pump fill station is available in two sizes: 4-16oz per stroke piston with 2 inch connections or 32-160oz per stroke piston with 3 inch connections.

- Volumes are adjusted using an external hand crank.
- USDA approved stainless steel construction
- Tilt mechanism allows for easy switching between kettles
- Locking swivel casters
- Pouch platform for support during filling

Closing assembly options

Available only from CMS! Angle seal dual element heat sealer

- 15 inch seal length
- Dual 1/4" wide band element
- Stainless steel frame
- Pneumatically operated
- Hercules water proof foot pedal
- Clean room compatible

Additional Options

- Spare Parts Kit
- Printer
- Waste bins
- The 16-64oz pump can be ordered with three different volume options
 - 4-16 oz per stroke piston
 - 8-32 oz per stroke piston
 - 16-64 oz per stroke piston



FLAVORSEAL
a CMS brand

02/01/10

FLAVORSEAL® Pumps and Pump Stations

Product Name: Mid-Size Pump with Angle Seal

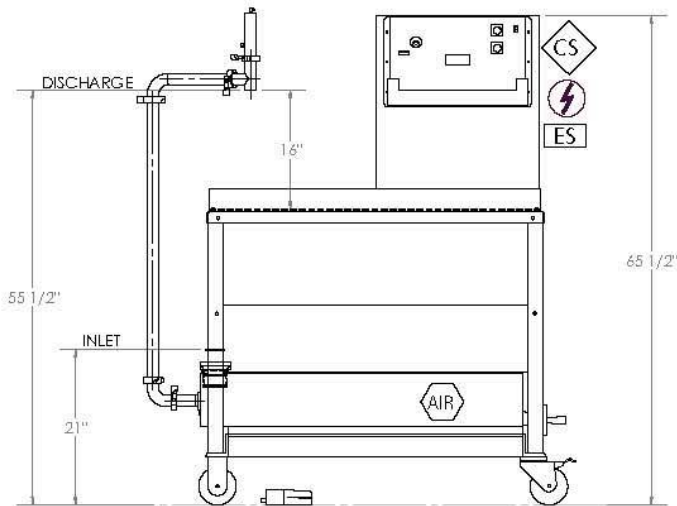
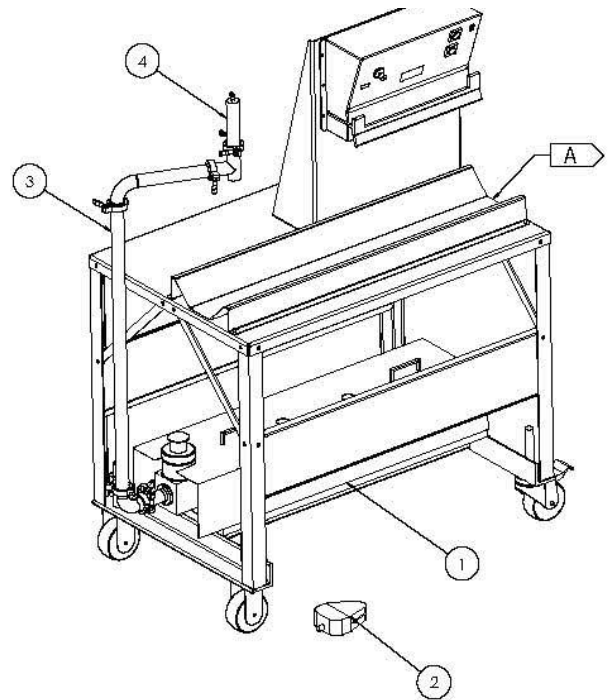
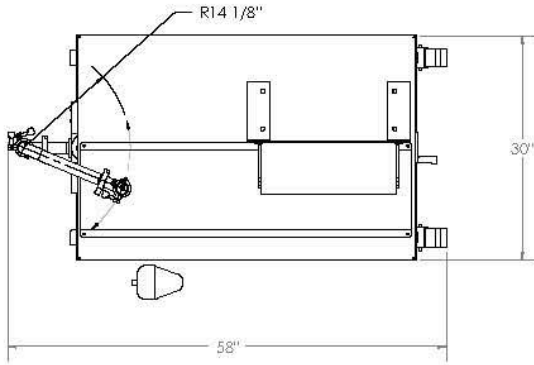

ITEM NO.	EQUIPMENT PROVIDED BY HINDS-BOCK	QTY
1	SP-64 PUMP FILLER	1
2	FOOT SWITCH, AIR	1
3	DISCHARGE PIPE, 1-1/2"	1
4	CUT-OFF SPOUT, 1-1/2"	1

NOTES:

ALL DIMENSIONS ARE FOR REFERENCE ONLY.
 SCFM: TO BE DETERMINED @ 90 PSI
 MAXIMUM ALLOWABLE PRESSURE DROP: 10 PSI
 POUCH SUPPORT PLATFORM

A

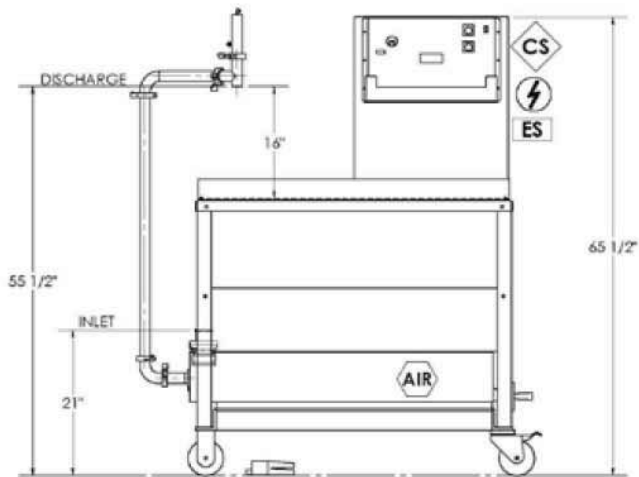

LEGEND

- [ES] E-STOP
- [AIR] AIR DROP: 1/2" NPT
- [⚡] POWER DROP
- [CS] CONTROL STATION